

# DOOR PREPARATION AND TEMPLATE FOR KNOB AND LEVER HANDLE PUSH PULL ROTATE LOCKSETS

• FITS DOORS 1-3/8" (35 mm) TO 1-3/4" (45 mm) THICK •



999-00321E EN

## TEMPLATE

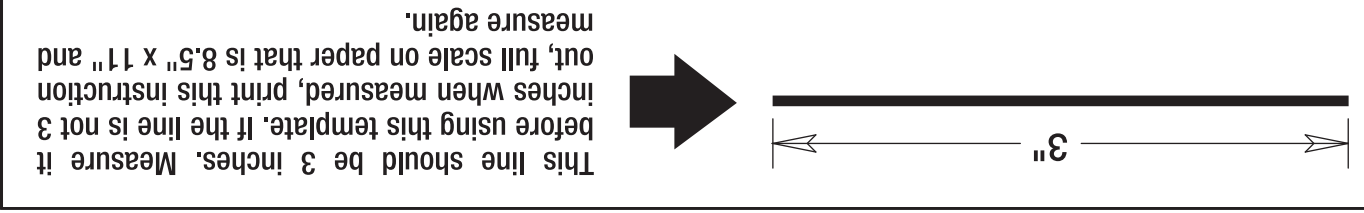
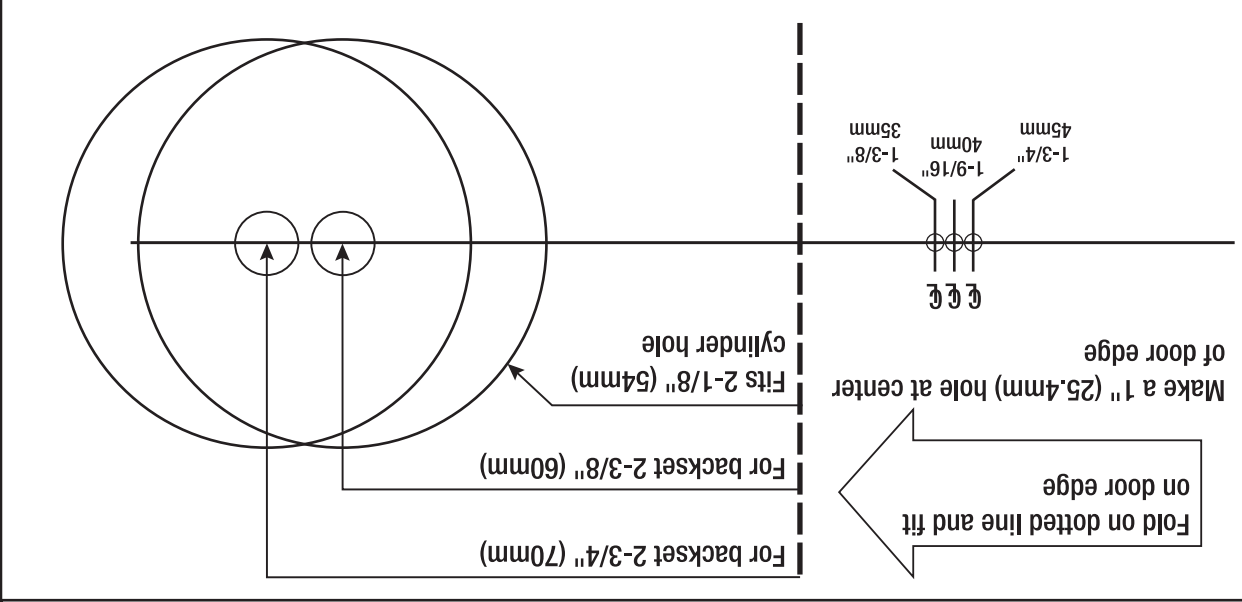

Brink's trademark & copyright works are used with permission.



**HAMPTON**  
50 Icon, Foothill Ranch, CA 92610-3000 USA  
email: info@hamptonproducts.com  
www.brinkspp.com 1-800-562-5625  
©2018 Hampton Products International Corp.  
999-00321E REV C 05/18

### STEP 1 Mark Door with Template

- Mark the center line for the lockset about 38" (965mm) from the floor.
- Select 2-3/8" (60mm) or 2-3/4" (70mm) backset as desired and mark center of hole on door face. (Most residential doors have a 2-3/8" backset.)

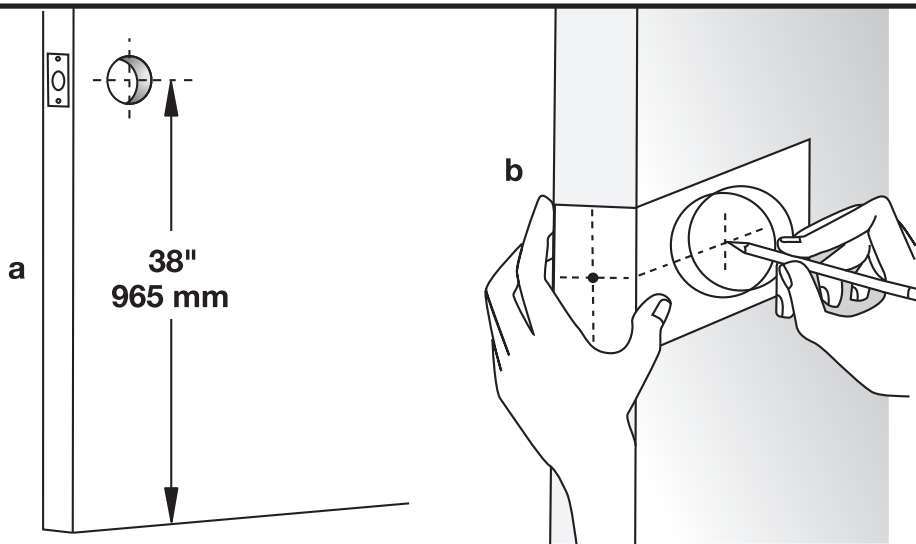

### STEP 2 Drill Holes

- Drill a 2-1/8" (54mm) hole on door face from both sides to avoid splitting the wood.
- Drill a 1" (25.4mm) hole for latch.
- Insert latch into hole, mark outline of faceplate, and chisel 1/8" (3.2mm) deep or until the faceplate is flush with the door edge.
- Mark latch screw holes and drill two 1/8" (3.2mm) pilot holes for the (S1) latch screws.

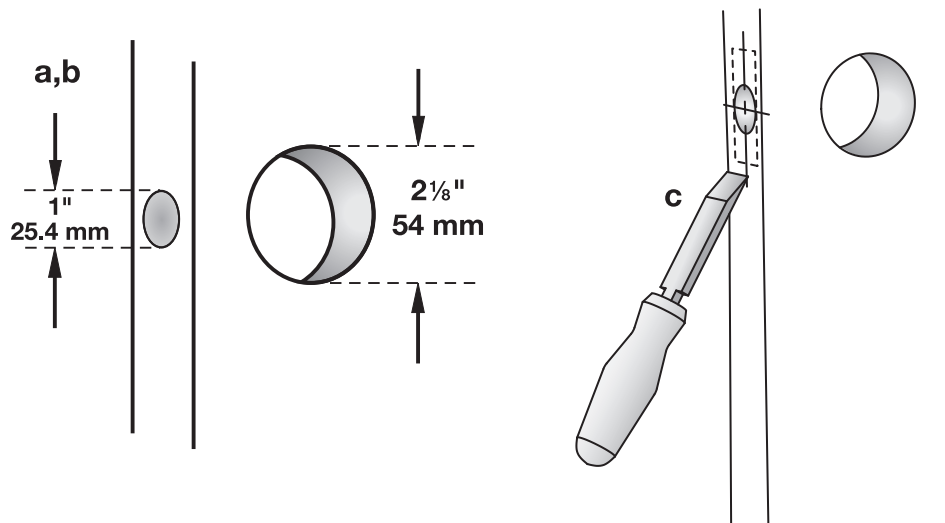

### STEP 3 Prepare Door Jamb for Strike Plate

- Mark centerline on the door jamb exactly opposite the latch hole.
- Drill two 7/8" (22mm) holes about 5/8" (16mm) deep. The holes should overlap by about 1/2" (13mm). Use a chisel to clean up the edges.
- Center the Strike Plate over the hole. Trace the outline with a pencil, then chisel the jamb approximately 1/16" (1.6mm) deep or until the Strike Plate is flush with the jamb.
- Place the Strike Plate back on the jamb. Make sure it is positioned correctly so that the Latch Bolt will move freely in and out of the Strike Plate. Mark the two screw hole locations and then drill two 1/8" (3.2mm) pilot holes.

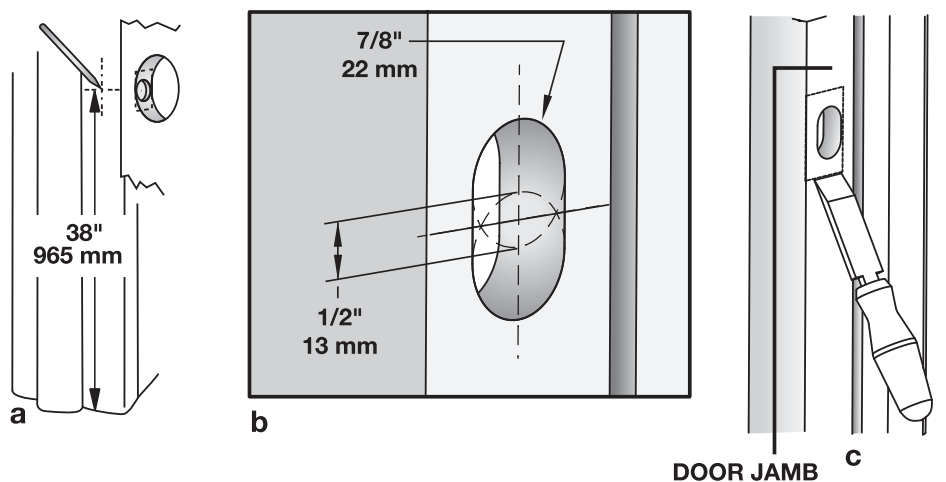

**CONFIRM THAT ALL HOLES HAVE BEEN PROPERLY PREPARED AND PROCEED TO THE HARDWARE INSTALLATION INSTRUCTIONS.**